



Improving Lightning Safety of Petroleum Storage Tanks

*Joseph A. Lanzoni
Lightning Eliminators & Consultants, Inc.
Boulder, Colorado USA
October 2009*

Summary

Fires involving petroleum storage tanks are not uncommon. About one-third of all tank fires are attributed to lightning. Floating roof tanks (FRT's) are especially vulnerable to lightning.

The American Petroleum Institute (API) created a technical committee to evaluate this situation and to recommend solutions. As a result, the API has issued a document entitled API RP 545, *Recommended Practice for Lightning Protection of Above Ground Storage Tanks for Flammable or Combustible Liquids*. It is expected that this document will transition into a standard in the near future.

The API 545 committee invested substantial resources into directed research and testing. Two of the key findings from the test program were that (1) when lightning current passes through shunts at the roof-shell interface, it will result in arcing under all conditions; and (2) it is the slow component of the lightning stroke which ignites flammable vapors. Therefore, when the slow component of a lightning stroke passes through any roof-shell interface, if flammable vapors are present they will likely be ignited. As a result, API RP 545 recommends three major modifications to FRT's:

1. Install *submerged* shunts between the roof and shell every 3 meters around the roof perimeter, and remove any existing above-seal shunts.
2. Electrically insulate all seal assembly components (including springs, scissor assemblies, seal membranes, etc.), and all gauge and guide poles, from the tank roof.
3. Install bypass conductors between the roof and shell no more than every 30 meters around the tank circumference. These bypass conductors should be as short as possible and evenly spaced around the roof perimeter.

Modifications #1 and #2 both require substantial design changes and overhauling of new and existing tank designs. Modifications #1 and #3 are methods to bond the roof and shell on FRT's. Modification #3, installation of bypass conductors, is relatively easy and inexpensive to implement when compared to the other modifications, and can be implemented immediately.

To meet the bypass conductor requirements, tank owners can choose between conventional conductors and retractable conductors wound on spring-tensioned reels. An FRT is most at-risk when the roof is high. Retractable bypass conductors will always be as short as possible, and offer substantially less impedance, when the FRT roof is high.

Lightning Eliminators & Consultants, Inc., of Boulder, Colorado, USA, has patented a retractable bypass conductor made specifically for FRT's, called the Retractable Grounding Assembly, or RGA. To substantially reduce lightning risk, RGA's should be installed on FRT's immediately, even though the tanks may not be overhauled for the other modifications for several years. Since it is the slow components of lightning strokes which ignite flammable vapors, and bypass conductors safely carry these slow components, modification #3 (installation of bypass conductors) should be implemented immediately. Installing RGA's on FRT's will eliminate the arcing at the shunts and other roof-shell interfaces caused by the slow components of the lightning stroke. Therefore, installing RGA's immediately will substantially reduce or eliminate the risk of lightning-related tank fires.

Background

Lightning-related petroleum storage tanks fires are more common than most people think. According to a review of petroleum storage tank fires between 1951 and 2003, the number of tank fires reported in the worldwide media is in the range of 15 to 20 fires per year. The extent of the tank fire incidents varies considerably, ranging from a rim seal fire to multiple, simultaneous full tank fires. Of the 480 tank fire incidents reported in the media, about one-third have been attributed to lightning. [Ref. 1] Another study, sponsored by 16 oil industry companies, found that 52 of 55 rim seal fires were caused by lightning, and concluded that "lightning is the most common source of ignition." [Ref. 2]

Two recent tank fires in the United States garnered much media attention. In the summer of 2008, a floating roof tank in Kansas City was ignited and burned for three days. During the summer of 2007, a floating roof tank in Wynnewood, Oklahoma, was also ignited. In both cases, lightning was the cause of ignition. In both cases, in addition to the huge cost of lost product, there were also numerous large, incalculable costs, including damage to the physical plant; interruption of customer service; environmental harm; firefighting, cleanup and rebuilding costs; EPA, OSHA and regulatory fines and increased oversight; loss of community goodwill, etc.

Floating Roof Tanks and Seals

Petroleum products such as crude oil, gasoline, diesel fuel, etc., are commonly stored in Floating Roof Tanks. An FRT is a type of tank where the roof floats on top of the product being stored. The roof, although it is constructed of steel, rests on pontoons that float on the product being stored. Consequently, as the tank is filled or drained, the roof travels up and down within the shell of the tank.

Flexible seals are fitted around the edge of the roof to prevent vapors from escaping. These seals are made of a non-conductive material, such as rubber, neoprene, etc. There are several different types of seal designs. A typical seal arrangement is shown in Figure 1, where two seals (called primary and secondary seals) are installed around the roof-shell

interface. The seal material, being non-conductive, electrically isolates the roof from the tank shell and from any connection to earth.

Unfortunately, these seals are not perfect. The seals become worn, cracked and/or damaged over time. In addition, the tank shell often becomes warped and out-of-round due to repeated filling, draining, heating, cooling, etc. The shell's inner surface can also become uneven from corrosion and/or petroleum residue, e.g. paraffin and tar.

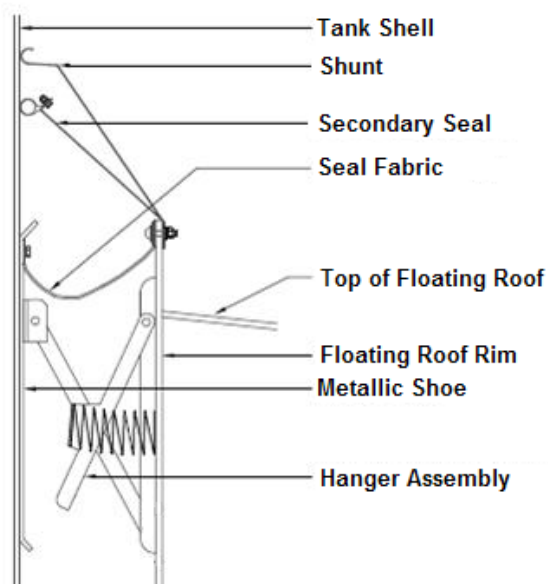

Figure 1: Cutaway of FRT Shell-Roof Seal Interface

Because of these imperfections around the roof-shell seal interface, petroleum vapor sometimes leaks out from around the seals and mixes with the air. Naturally, this vapor can be extremely combustible, which is why the region above the roof inside an FRT is classified as a Class I Division I area. The Class I Division I classification extends up from the roof to the top of the shell.

How Lightning Causes Tank Fires

Lightning strikes are characterized by very high stroke currents arriving in a very brief amount of time. For example, an average lightning strike delivers about 30,000 amps of electricity to ground within a few milliseconds. This current will flow across the surface of the earth until the cell between the thundercloud and earth is neutralized. The current will flow in all directions, although the amount will vary in proportion to the paths of lowest impedance. Some key lightning parameters are listed in Appendix One.

The mostly likely strike location on an FRT is the top of the rim or the gauge pole. However, lightning may endanger an FRT if a stroke terminates on (1) the roof, (2) the shell, (3) anything attached to the roof or shell, such as the gauge pole, or (4) a grounded structure or the earth near the FRT. If lightning terminates on any of these locations, or near an FRT, a portion of the total lightning current will flow across the roof-shell interface.

If lightning should terminate on the tank shell, as illustrated in Figure 2, sizable currents will flow across the roof-shell interface.

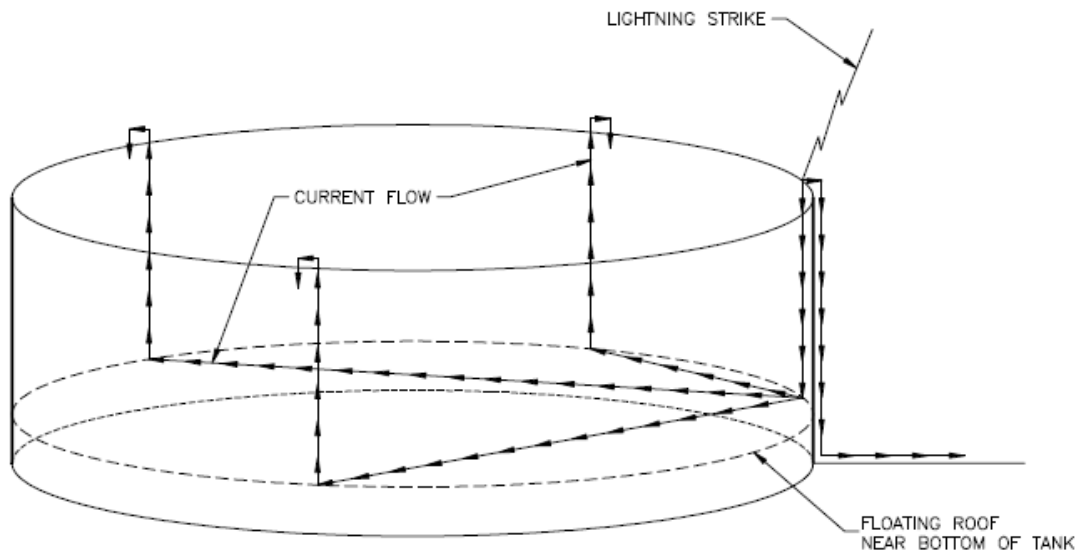

Figure 2: Illustration of Current Flows Resulting from Lightning Strike to Tank Shell (Note that current flows across the roof-shell interface in numerous locations.)

If lightning terminates near an FRT, either to the earth or to grounded structure as illustrated in Figure 3, smaller currents will flow across the roof-shell interface. In either case, lightning-related currents will flow across the roof-shell interface. If the impedance between the roof and shell is high, arcing will occur across the seal interface.

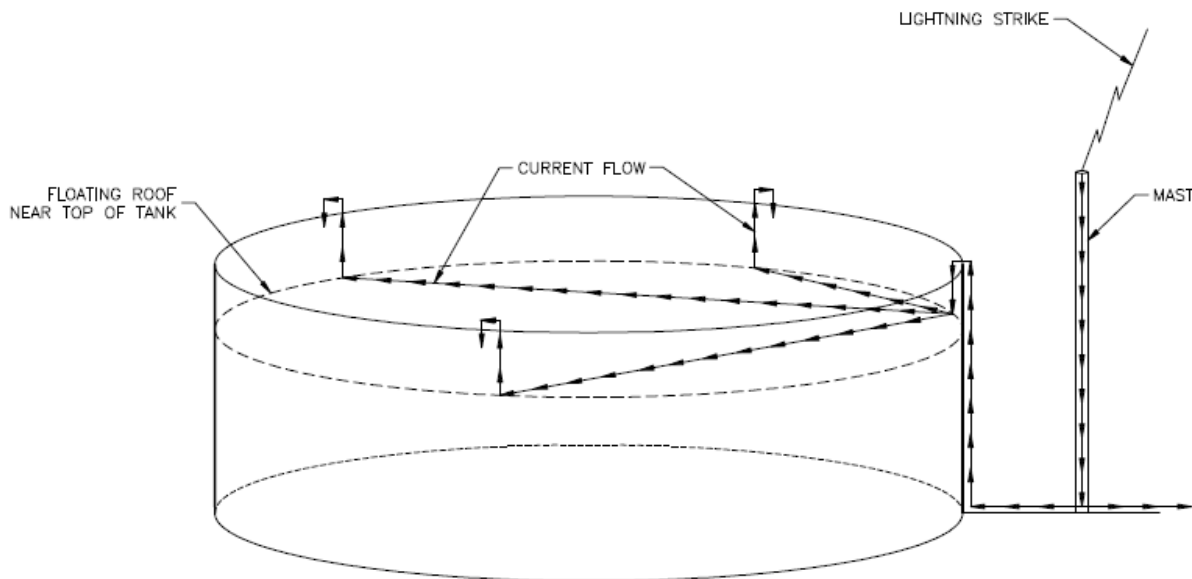

Figure 3: Illustration of Current Flows Resulting from Nearby Lightning Strike (Note that current flows across the roof-shell interface in multiple locations.)

A typical lightning stroke contains numerous components, as shown in Figure 4 and delineated in Table 1. The fast component, or first return stroke (Component A in the figure) is extremely brief yet contains the peak current. The long, slow component (Component C) contains less current than Component A, but is defined as the continuing current component. Component C lasts much longer than the other components and thus contains the most energy. *The slow Component C lasts 500 to 2,000 times longer than the fast Component A.*

Between Components A and C is a transitional, intermediate phase (Component B), where the current transitions from fast to slow. Following Component C, additional subsequent return strokes (Component D) typically occur, followed by additional Components B and C, etc., which typically continue to flow until the entire lightning flash is exhausted.

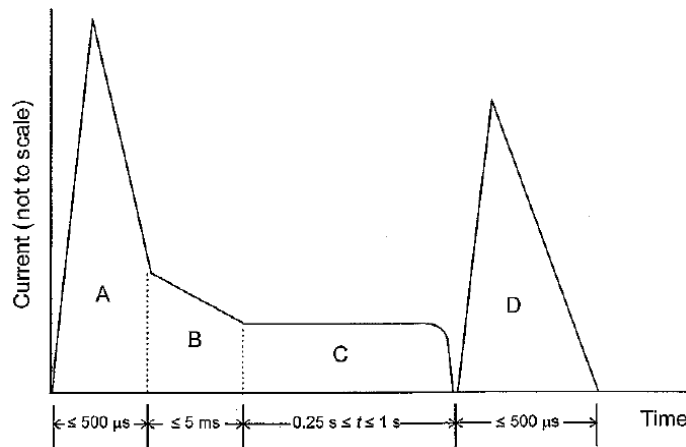

Figure 4: Lightning Flash Components (not to scale) [Ref. 3]

<u>Component</u>	<u>Amplitude,</u> <u>kiloamperes</u>	<u>Charge Transfer,</u> <u>coulombs</u>	<u>Duration,</u> <u>milliseconds</u>
A (first return stroke)	200 (+10%) peak	NA	≤ 0.5
B (intermediate current)	2 (± 20%) average	10 (± 20%) max	≤ 5
C (continuing current)	0.2 to 0.8	200 (± 20%)	250 to 1000
D (subsequent return stroke)	100 (± 10%) peak	NA	≤ 0.5

Table 1: Parameters of Lightning Flash Components [Ref. 3]

Bonding the Roof and Shell

It is imperative that the floating roof be electrically bonded to the tank shell, because the roof must be held at the same electrical potential as the tank shell. If the roof and shell are not at the same potential, and if the voltage between the two becomes great enough, then an arc will form between the two surfaces. This is the worst possible location of an arc, since flammable vapors may be present from imperfect seals.

Three Traditional Methods of Roof-Shell Bonding

1. Shunts

To create the roof-shell bond, FRT constructors usually install devices called “shunts.” Shunts are made from spring-tensioned steel. These shunts are attached to the roof so that they are in constant contact with the tank wall regardless of the position of the floating roof. The contact resistance depends on the characteristics of the shunt material, the contact pressure and the state of the tank wall.

NFPA 780, the *Standard for the Installation of Lightning Protection Systems*, requires that the shunts be spaced no more than every 3 meters around the roof perimeter, and that the shunts are constructed of 50 millimeter wide by 0.4 millimeter thick Type 302 stainless steel straps. [Ref. 4] The shunts are bolted to the edge of the floating roof and bent in such a way that the shunts press against the inside of the shell, thus making a contact connection with the shell. See Figure 5.

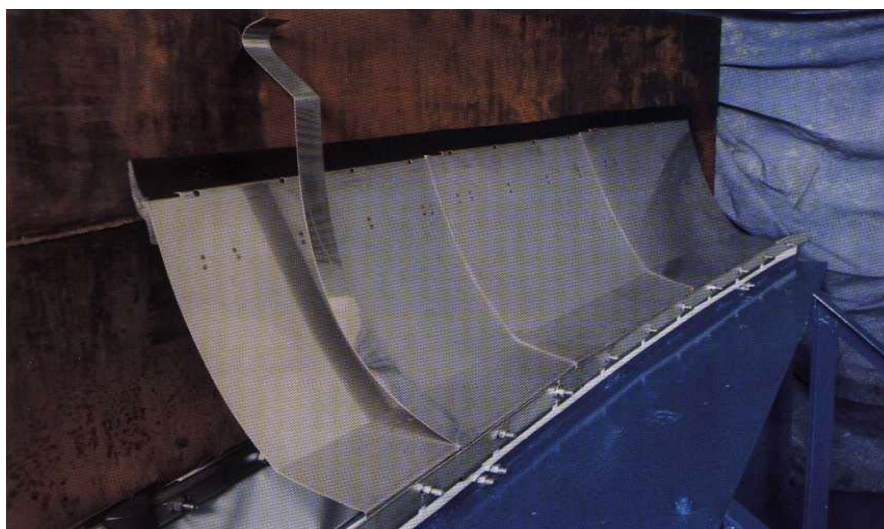

Figure 5: Cutaway of FRT Showing Shunt above Seals

Unfortunately, shunts do not provide a positive, low impedance bond to the tank shell for several reasons, including:

1. Heavy crude oil components, such as wax, tar, paraffin, etc., tend to coat the inside of the tank wall, thus forming a resistive barrier between the shell and shunts.
2. Corrosion (rust) on the inside of the shell will create a high resistance connection between the shell and shunts.
3. About 10 to 25% of all FRT's are painted on the inside, typically with an epoxy-based paint. Whether or not to paint the inside of the tank is defined by the tank contents and corrosion considerations. If the inside of the tank is painted, the paint will insulate the shell from the shunts.

4. Large tanks are typically out-of-round by several inches. If a tank is elongated for some reason, the shunts will be pulled away from the shell in the long dimension of the tank. See Figure 6.



Figure 6: Shunt Not Making Contact with Out-of-Round Tank Shell

Independent third-party testing, performed in cooperation with the API and the Energy Institute in England, has shown that arcing will occur at the shunt-shell interface under all conditions; it does not matter if the shunts are clean or dirty, new or old, neglected or well-maintained. It also does not matter if the inner shell walls are clean, rusty, painted or coated; arcing will occur in all situations. See Figure 7.

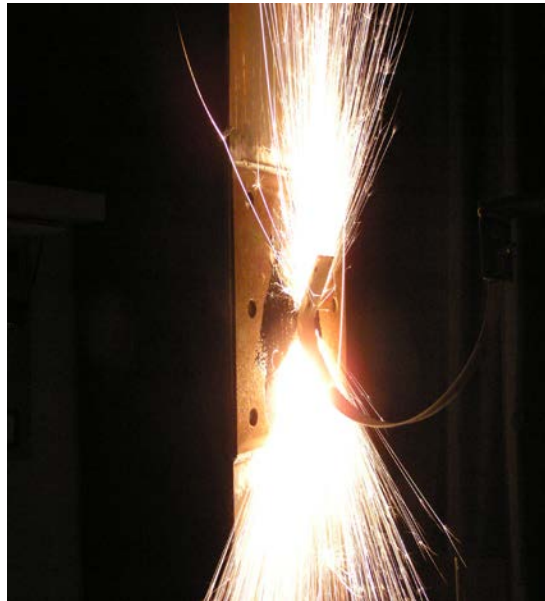

Figure 7: Electrical impulse test of shunt to simulated tank wall.

Arcing can be expected between the shunts and inner tank wall under all conditions, whether or not the shunts are above the roof or submerged. If the shunts are above the roof,

the location of the arcing is in the worst possible location: In a Class I Division I location which may have a high concentration of fuel-air vapor.

2. Walkway

Another way to create the roof-shell bond is to rely on the walkway from the top of the shell to the roof. Nearly all FRT's have a walkway or ladder with the upper end attached to the rim of the tank, and the other lower end riding on rails mounted to the roof. See Figure 8. As the floating roof raises and falls, the lower end of the walkway moves radially to compensate for the change in height of the roof.

The quality of the electrical connection via the walkway is questionable. The upper end of the walkway is a bolted hinge and is subject to looseness, corrosion and paint. The electrical connection on the lower end is a pressure connection through only the two wheels riding on rails. This connection is also subject to corrosion and paint.



Figure 8: Walkway on FRT

3. Roof-Shell Bonding Cable

A third way to create a roof-shell bond is to install a bonding cable between the top of the shell and the middle of the roof. This cable is typically a 2/0 to 250 MCM sized conductor. The roof-shell bonding cable is typically attached to the top of the rim near the top of the walkway, suspended along the bottom of the walkway, and bonded to the center of the roof. The cable must be long enough to accommodate the roof in its lowest position.

For example, for a 200 foot (61 meter) diameter tank 50 feet (15.2 meters) high, the cable must be at least 112 feet (34 meters) long to reach the center of the roof when the tank is empty. Although at 60 hertz this cable will have low impedance, at lightning frequencies this cable will have very high impedance. Therefore, during lightning events when thousands of

amps of electricity may be flowing across the tank, the impedance of the roof-shell bonding cable is too high to prevent sustained arcing at the shunts.

API Response

Because of the high incidence of lightning related tank fires, the American Petroleum Institute (API) formed a technical committee to investigate the cause of these fires, evaluate tank designs and write a standard to force changes in petroleum storage practices to reduce or eliminate lightning related tank fires. The committee examined all of the variables which contribute to lightning-related tank fires, including direct strike protection, grounding, bonding, etc. The committee also contracted with a testing company (Culham Electromagnetics and Lightning Ltd., of Oxfordshire, United Kingdom) to perform directed research on floating roof tanks. This API sponsored testing proved that *shunts will arc under all conditions*, whether they are clean, dirty, rusty, well-maintained, etc., and led to the following official warning from API [Ref. 5]:

Per NFPA 780 (Lightning Protection Code), shunts are required to be installed on floating roof tanks above the seal at 3 meter (10 feet) spacing around the tank perimeter. The purpose of these shunts is to provide a conductive path from the tank roof to the tank wall. Tests conducted for the API RP 545, "Lightning Protection for Above Ground Storage Tanks", task group have shown that these shunts can generate showers of sparks during lightning strikes. If there is a gap between the seal and the tank wall during a lightning strike and if a flammable mixture is present, a tank fire may result.

Other key findings of the test program included the following:

1. The fast component of the lightning stroke did not cause ignition of flammable vapors, whereas the long duration component did cause ignition. [Ref. 6] The fast component of the lightning stroke is too brief and has too little energy to ignite flammable vapors.
2. Bypass conductors will carry the intermediate and long duration components of the lightning stroke. [Ref. 7] If these components were allowed to continue to flow through the shunts, sustained, hazardous arcing would occur at the shunts, which would ignite any flammable vapors present.

API Recommendations

After years of testing and deliberation, in October 2009 the API published a document intended to address these concerns. The resulting API document is entitled API RP 545, *Recommended Practice for Lightning Protection of Above Ground Storage Tanks for Flammable or Combustible Liquids*. It is expected that this RP will transition to a standard in the near future.

API RP 545 makes three key recommendations to improve the lightning safety of petroleum storage tanks with external floating roofs, as follows:

1. Install *submerged* shunts between the roof and shell every 10 feet (3 meters) around the roof perimeter. The shunts should be submerged by one foot (0.3 meters) or more, and if existing above-seal shunts are present, they should be removed.
2. Electrically insulate all seal assembly components (including springs, scissor assemblies, seal membranes, etc.), and all gauge and guide poles, from the tank roof. The insulation level should be 1kV or more.
3. Install bypass conductors between the roof and shell no more than every 30 meters (100 feet) around tank circumference. These bypass conductors should be as short as possible and evenly spaced around the roof perimeter. They should have a maximum end-to-end resistance of 0.03 ohms and be of the minimum length necessary to permit full movement of the floating roof.

Evaluation of API RP 545 Recommendations

1. Submerged Shunts: Shunts are used for the conduction of the fast and intermediate duration components of the lightning stroke current.

The API acknowledges that arcing occurs between the shunt and shell during all lightning events. However, this arcing is dangerous only when a flammable vapor is present. If the shunt is submerged, then theoretically the arcing will occur where no air/oxygen is present, and ignition will be avoided.

2. Insulation of Seal Components and Poles: Insulating these components will encourage lightning currents to travel through preferential paths (shunts and bypass conductors) rather than arcing between the roof and shell. In other words, all possible current paths must be limited to those preferential paths between the roof and shell, i.e., the shunts and bypass conductors. However, it is debatable if the recommended insulation level of one kilovolt will be sufficient to cause the desired outcome. The test report specifically recommends an insulation level of “tens of kV and a flashover distance of at least 75mm.” [Ref. 8] As a point of reference, air has an electrical breakdown of 3kV per millimeter.
3. Bypass Conductors: Bypass conductors are used for the conduction of the intermediate and long duration components of the lightning stroke current.

One of the observations from testing was that the fast component of the lightning stroke did *not* ignite flammable vapors, and that it was the long component of the lightning stroke that caused ignition. With conventional, above-seal shunts, the sustained arc at the shunts lasted long enough to ignite flammable vapors. Because bypass conductors will provide a positive bond between the roof and shell, the bypass conductors will present a lower impedance connection between the roof and

shell, as compared to the shunts. Therefore, the long component of the lightning current will be diverted away from the shunts and through the bypass conductors.

Impact of API RP 545 Recommendations

1. **Submerged Shunts:** Providing submerged shunts on new tanks will require substantial design changes from existing standard designs. On existing tanks, *the changeover from above-seal to submerged shunts will be very costly and will require major overhauls.* The tanks will need to be emptied and personnel will need to go inside the tank, both above and below the roof, for substantial periods of time to make the necessary modifications. In addition, because they are submerged, these shunts will be extremely difficult to inspect and maintain.
2. **Insulation of Seal Components and Poles:** Similar to No. 1 above, i.e., substantial design changes and costly field modifications will be required, with attendant inspection and maintenance issues.
3. **Bypass Conductors:** Of the three API recommendations, the installation of bypass conductors is relatively easy and inexpensive, on both existing and new tanks. Existing tanks can be retrofitted with bypass conductors while still in service, regardless of the level of the roof. Because they are external, bypass conductors are easy to inspect and maintain.

Types of Bypass Conductors

In response to these requirements, the marketplace has provided tank owners with a choice between two different types of bypass conductors: (1) a conventional fixed length, stranded conductor or (2) a retractable conductor wound on a spring-tensioned reel.

The ideal bond between the FRT roof and shell would have a low impedance across a wide range of frequencies. The ideal bond would also be easy to install on new tanks and to retrofit onto existing tanks. The ideal bond would also be easy to inspect and test, and to replace if necessary.

LEC has developed a roof-shell bonding mechanism that fulfills all of these requirements. The LEC Retractable Grounding Assembly (RGA) provides the lowest possible impedance bond between the floating roof and tank shell. It is easy to install on both new and existing tanks. It is also easy to inspect, test and maintain. The RGA has been patented for use on FRT's by Lightning Eliminators & Consultants, Inc., of Boulder, Colorado USA. See Figure 9.



Figure 9: LEC Retractable Grounding Assembly (RGA) on Floating Roof Tank

The RGA has a spring-loaded cable that attaches between the roof and shell. The bonding cable on an RGA is constructed of a wide, flat braided copper cable. The RGA housing is entirely stainless steel for excellent corrosion protection. The flat braided cable on an RGA is constructed from 864 strands of #30AWG (0.05 square millimeter) copper wire, braided together to form a strap 1.625 inches (41 millimeters) wide by 0.11 inches (2.8 millimeters) thick. The cable is tinned for additional corrosion protection.

The cable on the RGA is spring-tensioned, meaning that it automatically retracts on the reel when it is not under tension. Therefore, the cable is always as short as possible, regardless of the position of the roof. In other words, the RGA is always “*of the minimum length.*” Because the RGA body attaches to the top of the shell, and the cable attaches to the roof, it is independent of the condition of the tank wall and that of any shunts. It also works if no shunts are present.

Since FRT’s tend to be of very large diameter, it is important to limit the roof-to-shell impedance by installing multiple RGA’s. The recommended quantity of RGA’s is shown in Table 3:

Tank Circumference, meters	Tank Diameter, meters	Quantity of Required RGA's
≤ 60	≤ 19.10	2
≤ 90	≤ 28.65	3
≤ 120	≤ 38.20	4
≤ 150	≤ 47.75	5
≤ 180	≤ 57.30	6
≤ 210	≤ 66.84	7
≤ 240	≤ 76.39	8
≤ 270	≤ 85.94	9
≤ 300	≤ 95.49	10
≤ 330	≤ 105.04	11
≤ 360	≤ 114.59	12

≤ 390	≤ 124.14	13
≤ 420	≤ 133.69	14
≤ 450	≤ 143.24	15
≤ 480	≤ 152.79	16
≤ 510	≤ 162.34	17
≤ 540	≤ 171.89	18
≤ 570	≤ 181.44	19
≤ 600	≤ 190.99	20

Table 3: Recommended RGA Quantities

Comparing Conventional and Retractable Bypass Conductors

An FRT is most at risk, and all of the hazards from lightning tend to be worse, when the roof is high. [Ref. 9] During these conditions (when the tank is full or nearly full), the lightning current flows will be concentrated in the shunts directly below the lightning strike location, as illustrated in Figure 10. For example, if a 30kA lightning strike terminates directly above a shunt when the roof is high, about 11kA of the lightning current will pass through that one shunt. If a lightning strike terminates directly between two shunts when the roof is high, about 7kA will pass through each of the two nearest shunts. [Ref. 10] In comparison, when the tank’s roof is low and a lightning strike terminates on the tank, the lightning current disperses and is more evenly distributed among the available roof-shell bonds, as illustrated in Figure 11.

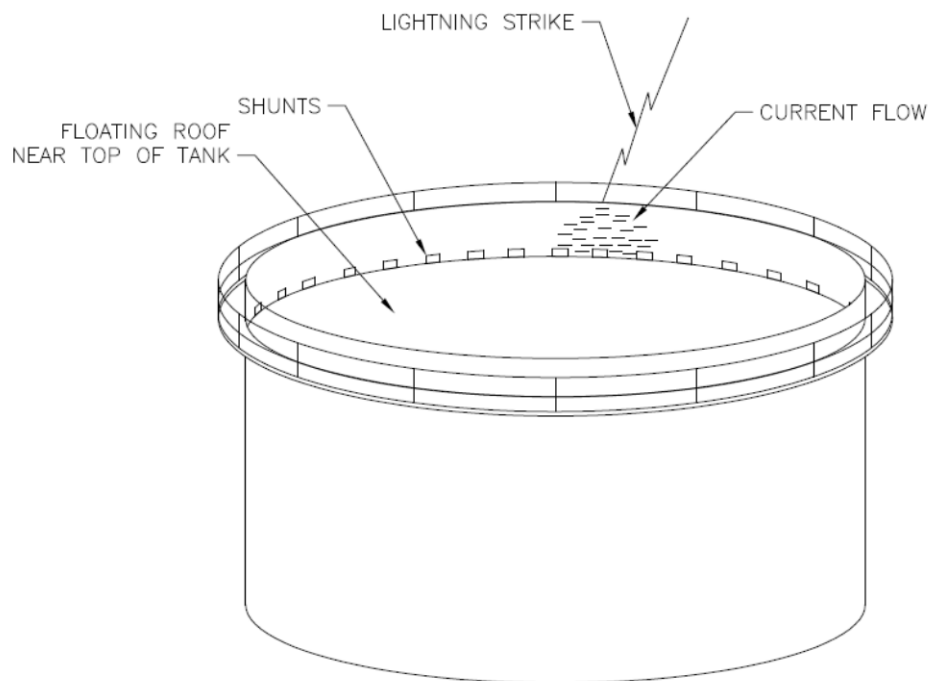

Figure 10: Concentration of Lightning Current Flow when Roof is High

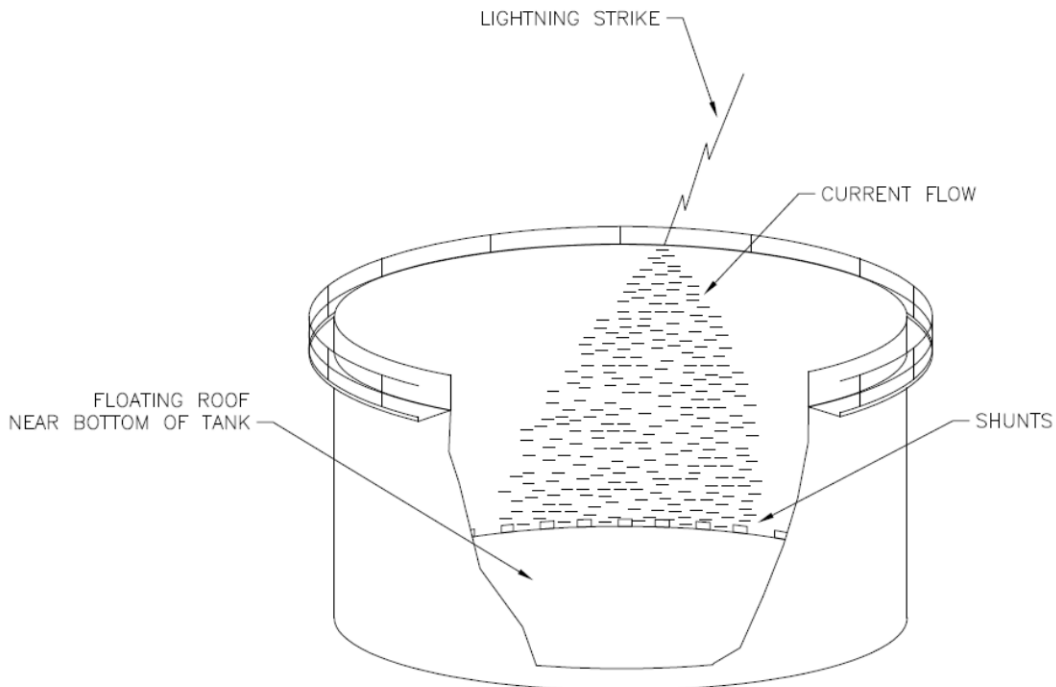

Figure 11: Dispersion of Lightning Current Flow when Roof is Low

Now compare the impedance of the two types of bypass conductors (conventional and retractable) during high-roof and low-roof conditions. During high-roof conditions, *when the tank is most at risk*, the conventional bypass conductor will be randomly splayed and coiled on the tank roof, as illustrated in Figure 12. In addition, if the conductor is not insulated, accidental sparking may occur where the loose conductor contacts itself and other parts of the roof. [Ref. 11] In comparison, when the roof is high the RGA conductor will be as short as possible, as shown in Figure 13, and provide about one-sixth of the impedance of conventional bonding cables. API RP 545 requires that the bypass conductors be “...of the minimum length necessary...” [Ref. 12] Therefore, when the tank is most at-risk, and when the owner has the most content to lose, the RGA will have the lowest possible impedance. See Appendix Two, *Impedance Comparison of Conventional and Retractable Bypass Conductors*..

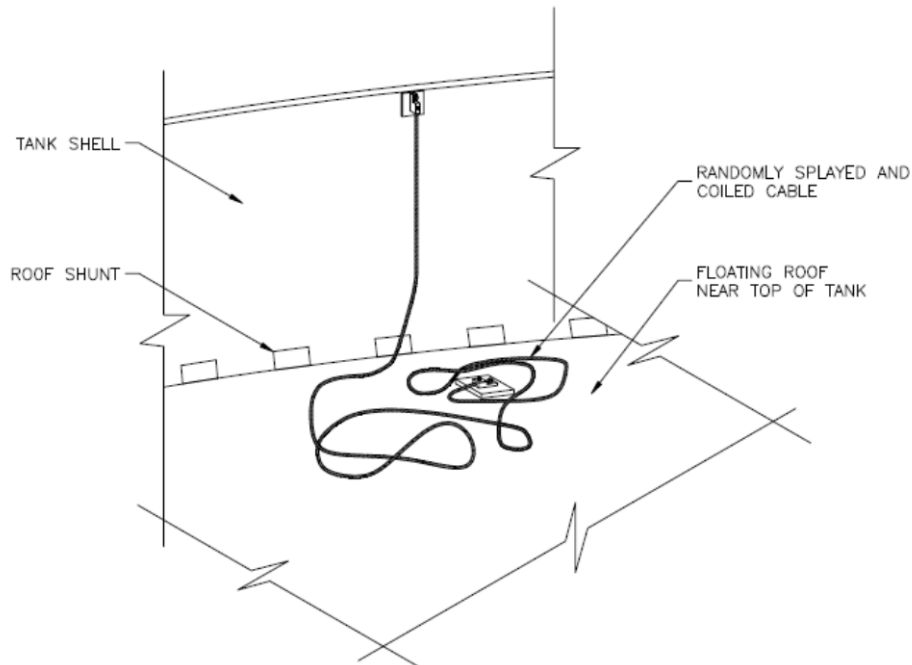

Figure 12: Conventional Cable as Bypass Conductor

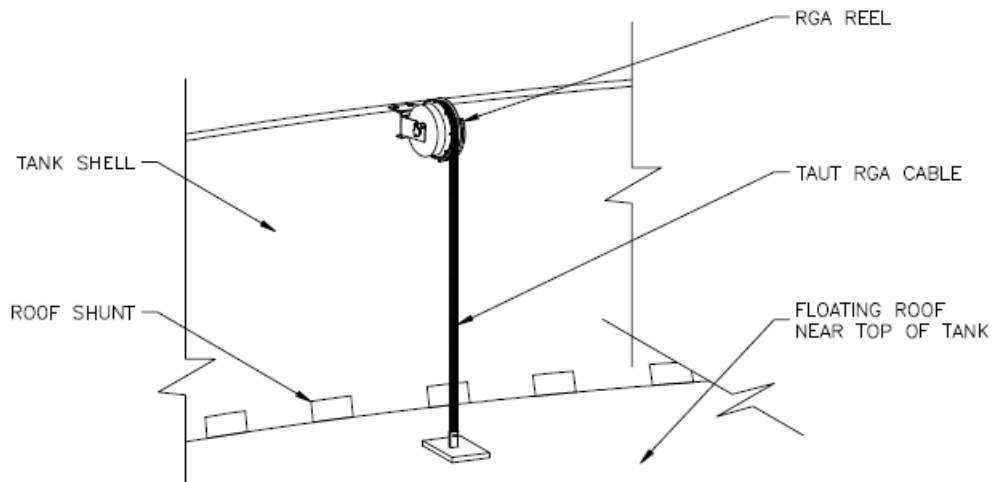

Figure 13: RGA as Bypass Conductor

What Does This Mean for FRT's?

Suppose a lightning strike terminated on or near an FRT. The strike current would flow across all of the roof-shell connections, including through the shunts, bypass conductors and any other incidental roof-shell connections. The lower the impedance of the bypass conductors, the sooner the lightning current will transition from the shunts and incidental connections (which is UNDESIRABLE) to the bypass conductors (which is DESIRABLE). This may mean the difference between the ignition and survival of the FRT.

APPENDIX ONE

Key Lightning Parameters

[References 13 and 14]

Peak Current, negative first strokes (50 th percentile)	30,000 Amps
Peak Current, negative first strokes (95 th percentile)	80,000 Amps
Flash Duration, negative flashes (50 th percentile)	13 milliseconds
Flash Duration, negative flashes (95 th percentile)	1100 milliseconds
Range of Strokes per Flash	1 to 30
Average Number of Strokes per Flash	3 to 4
Peak Temperature	> 50,000° F

The upper limit parameters usually employed for lightning strokes are as follows [Ref. 15]:

- Current (I) = 200,000 amperes
- Total charge = 200 coulombs
- Rate of change of current (di/dt) = 140kA/μs
- Action integral = 2.25x10⁶ A²s

APPENDIX TWO

Impedance Comparison of Conventional and Retractable Bypass Conductors

Background

The impedance (Z) of a conductor is shown by Equation (1), the inductive reactance (X_L) of a conductor is shown by Equation (2) and the inductance (L) of a straight wire is shown by Equation (3), as follows:

$$Z = \sqrt{R^2 + X_L^2 + X_C^2} \tag{1}$$

$$X_L = 2\pi f L_1 \tag{2}$$

$$L_2 = 2l \left[2.303 \log \left(\frac{4l}{d} \right) - 1 + \frac{\mu}{4} + \left(\frac{d}{2l} \right) \right] \tag{3}^*$$

- where
- Z = impedance in ohms
 - R = resistance in ohms
 - X_L = inductive reactance in ohms
 - X_C = capacitive reactance in ohms
 - f = frequency in hertz
 - L₁ = inductance in henries
 - L₂ = inductance in nanohenries
 - l = length of wire in centimeters
 - d = diameter of wire in centimeters

μ = permeability of material (= 1.0 except for ferromagnetic materials)

When applying these equations to lightning circuits, note that the capacitive reactance (X_c) is essentially zero, and that the resistance of a relatively short, large diameter conductor is negligible when compared to its inductive reactance. Therefore, the impedance of a conductor during a lightning event is essentially equal to its inductive reactance.

The ratio of the impedance of the conventional conductor to the impedance of the retractable conductor would essentially be equal to the ratio of their inductive reactances, or:

$$\frac{Z_{conventional}}{Z_{retractable}} \simeq \frac{X_{Lconventional}}{X_{Lretractable}} = \frac{2\pi f L_{conventional}}{2\pi f L_{retractable}} = \frac{L_{conventional}}{L_{retractable}} \quad (4)$$

Impedance of Conventional and Retractable Bypass Conductors

The inductance of a conventional bypass conductor, constructed of #1 AWG wire, on a 50 foot tall tank, is 25,218 nanohenries *when the wire is straight*. When the roof is 40 feet high and the wire is randomly coiled and splayed, the inductance would be considerably higher.

However, if a retractable #1 AWG bypass conductor was used instead of a conventional bypass conductor, when the roof is 40 feet high the conductor would be only 10 feet long, and its inductance would be only 4,063 nanohenries.

Therefore, under these parameters, the impedance of the conventional conductor is ***MORE THAN SIX TIMES*** the impedance of the retractable conductor. Naturally, the taller the tank, the greater the difference in impedances between conventional and retractable conductors, when the roof is high.

* [Ref. 16]

REFERENCES

1. Henry Persson and Anders Lönnermark, *Tank Fires, Review of Fire Incidents 1951–2003*, Brandforsk Project 513-021.
2. Large Atmospheric Tank Fires (LASTFIRE), *Project Analysis of Incident Frequency Survey*, June 1997.
3. SAE ARP (Aerospace Recommended Practice) 5412, *Aircraft Lightning Environment and Related Test Waveforms*, SAE Publications, USA, 2000.
4. NFPA 780 *Standard for the Installation of Lightning Protection Systems*, 2008 Edition, Paragraph 7.4.1.2.
5. API Committee on Refining Equipment website, <http://committees.api.org/standards/cre/soee/soeehm.html>, Notifications and Updates, FRT Shunt Test Update September 2006.
6. API/EI Research Report 545-A *Verification of lightning protection requirements for above ground hydrocarbon storage tanks*, First Edition, October 2009, Summary, Phase 2:4.
7. Ibid., Summary, Phase 2:3.
8. Ibid., Summary of current flow and sites of arcing in floating roof tanks, Phase 2.iii.
9. Ibid., Summary, Section 2.2, Phase 1:13.
10. Ibid., Section 6.1.1, Phase 1:51.
11. Ibid., Section 3.2, Phase 1:47.
12. API RP 545 *Recommended Practice for Lightning Protection of Above Ground Storage Tanks for Flammable or Combustible Liquids*, First Edition, October 2009, Section 4.2.1.2.2.
13. Uman, Martin, *The Lightning Discharge*, Table 7.2, page 124.
14. Uman, Martin, *All About Lightning*, page 41.
15. API RP 545 *Recommended Practice for Lightning Protection of Above Ground Storage Tanks for Flammable or Combustible Liquids*, First Edition, October 2009, Section A.1.3.
16. *CRC Handbook of Chemistry and Physics*, 44th Edition, Dr. David R. Lide, Chemical Rubber Publishing Co., Cleveland, OH, 1962.